

PRODUCT INFORMATION PACKET

Model No: 113256.00

Catalog No: 113256.00

0.33 HP Agricultural Motor, 1 phase, 1800 RPM, 115/208-230 V, 56 Frame, TEFC



Regal and are trademarks of Regal Rexnord Corporation or one of its affiliated companies.
©2022 Regal Rexnord Corporation, All Rights Reserved. MC017097E

Nameplate Specifications

Output HP	0.33 Hp	Output KW	0.25 kW
Frequency	60 Hz	Voltage	115/208-230 V
Current	6.4/3.4-3.2 A	Speed	1725 rpm
Service Factor	1.15	Phase	1
Efficiency	62 %	Power Factor	55
Duty	Continuous	Insulation Class	B
Design Code	L	KVA Code	M
Frame	56	Enclosure	Totally Enclosed Fan Cooled
Thermal Protection	Manual	Ambient Temperature	40 °C
Drive End Bearing Size	6203	Opp Drive End Bearing Size	6203
UL	Recognized	CSA	Y
CE	N	IP Code	54
Number of Speeds	1		

Technical Specifications

Electrical Type	Capacitor Start Induction Run	Starting Method	Across The Line
Poles	4	Rotation	Selective Counterclockwise
Resistance Main	0 Ohms	Mounting	Rigid Base
Motor Orientation	Horizontal	Drive End Bearing	Ball
Opp Drive End Bearing	Ball	Frame Material	Rolled Steel
Shaft Type	NEMA 56	Overall Length	10.48 in
Frame Length	5.50 in	Shaft Diameter	0.625 in
Shaft Extension	1.88 in	Assembly/Box Mounting	F1 ONLY
Outline Drawing	028774-550A	Connection Drawing	005003.03

This is an uncontrolled document once printed or downloaded and is subject to change without notice. Date Created:06/08/2022

This document is the property of REGAL BELOIT CORPORATION ("RBC") including its subsidiaries and divisions and contains proprietary information of RBC. This document is loaned on the express condition that neither it nor the information contained therein shall be disclosed to others without the express written consent of RBC, and that the information shall be used by the recipient only as approved expressly by RBC. This document shall be returned to RBC upon its request. This document may be subject to certain restrictions under U.S. export control laws and regulations.

NOTES:

- 1) MANUAL OVERLOAD PROTECTOR.
- 2) FLINGER ON SHAFT.
- 3) GASKETS THROUGHOUT.
- 4) DRAIN HOLE IN FRAME (BOTH ENDS).

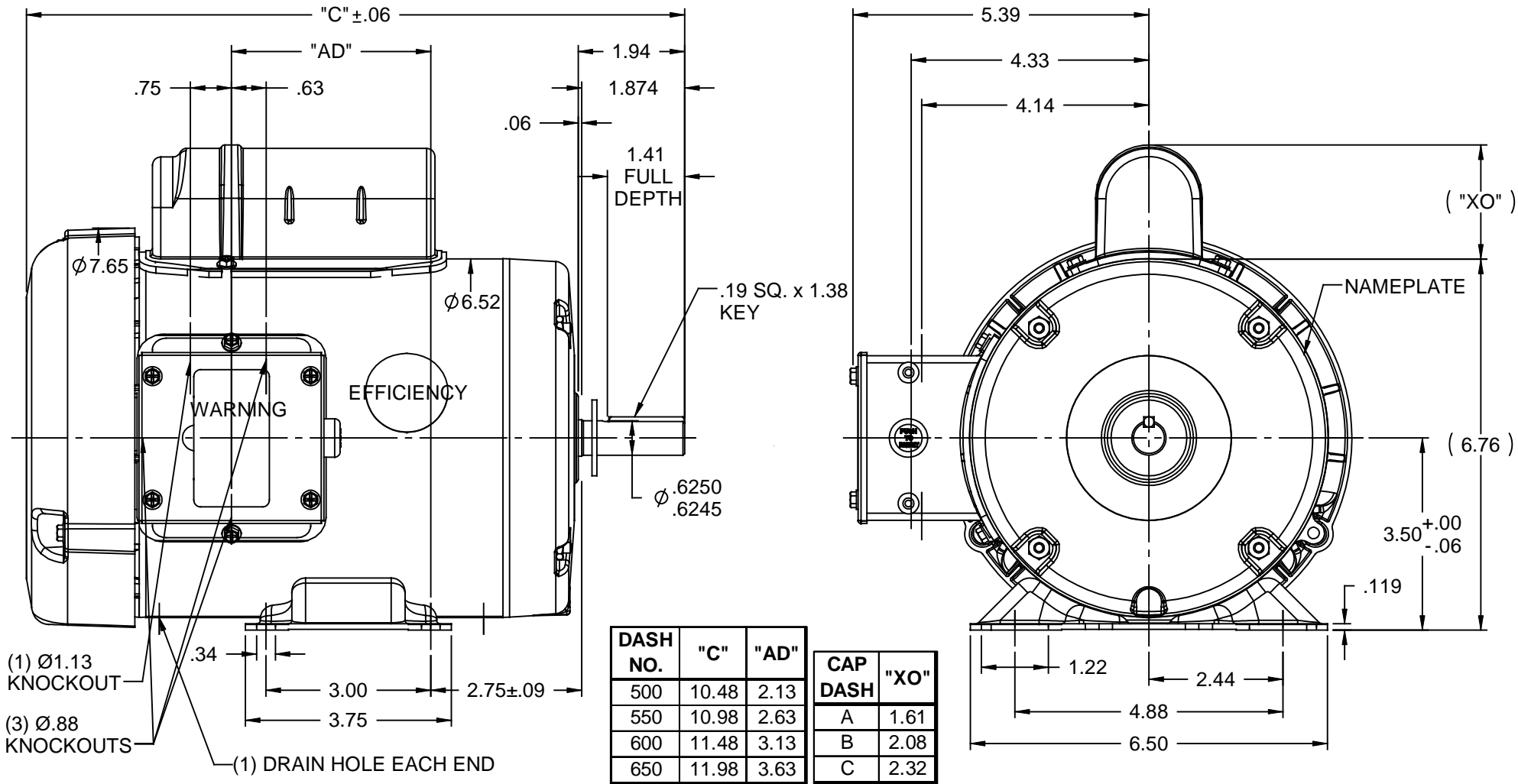

		TOLERANCES UNLESS SPECIFIED		ELECTRIC MOTORS GEARMOTORS AND DRIVES	DRAWN KMM 08/09/07
		DEC	INCHES		CHK
		.X	±.1		APPR
		.XX	±.03		SCALE 3:8
		.XXX	±.005		REF 032507
01	ADD DRAIN HOLE NOTE PER ISAAC 08-1915	LST 5/7/08	XX .XXXX ±.0005	MAT'L	FMF 110088.00
NO	REVISION	BY & DATE	CHK ANG ±1/2°	FINISH GENERAL PURPOSE	PAGE OF
THIRD ANGLE PROJECTION			RFP	PREV	SIZE A
			NETWORK FILE NAME	DRAWING NO	REV 01
				028774	

VIEW FROM OUTSIDE OF MOTOR AT SWITCH END



LINE LEADS

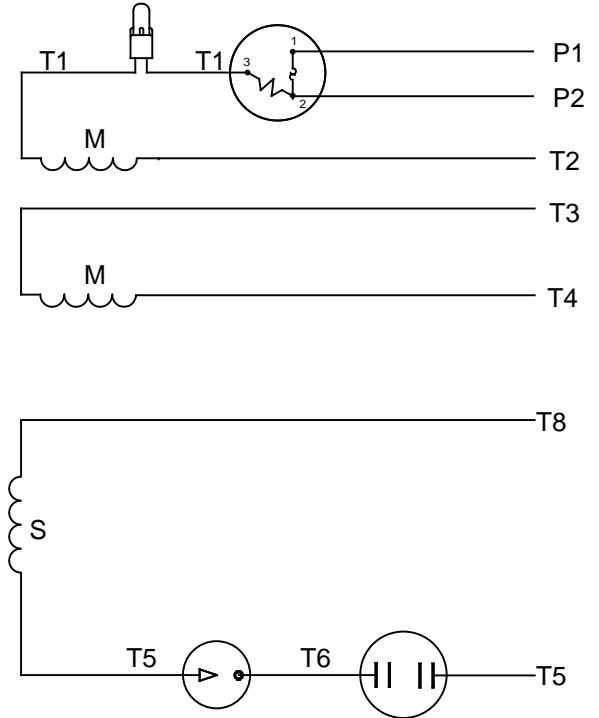

RBC PROPRIETARY AND CONFIDENTIAL INFORMATION
 This document is the property of REGAL BELOIT CORPORATION ("RBC") including its subsidiaries and divisions and contains proprietary information of RBC. This document is loaned on the express condition that neither it nor the information contained therein shall be disclosed to others without the express written consent of RBC, and that the information shall be used by the recipient only as approved expressly by RBC. This document shall be returned to RBC upon its request. This document may be subject to certain restrictions under U.S. export control laws and regulations.

	ROTATION FACING LEAD END	L1	L2	JOIN	INSULATE SEPARATELY
HIGH VOLT	C.C.W.	P1	T4 T5	T2,T3 T8	P2
	C.W.	P1	T4 T8	T2,T3 T5	P2
LOW VOLT	C.C.W.	P1	T2,T4 T5	P2,T3 T8	---
	C.W.	P1	T2,T4 T8	P2,T3 T5	---

		TOLERANCES UNLESS SPECIFIED		LEESON	ELECTRIC MOTORS GEARMOTORS AND DRIVES	DRAWN	
NO	REVISION	DEC	INCHES			WLV	08/20/79
		.X	±.1			CHK	ADN 08/27/76
		.XX	±.01			APPR	WRK 08/27/76
06	REDRAWN IN SOLIDWORKS	VJB	7/22/2011	.XXX	±.005	TITLE	EXTERNAL WIRING DIAGRAM TYPE "C" W/PROTECTOR
05	REDRAWN ON CAD	DBT	05/27/97	.XXXX	±.0005	MAT'L	DECAL - 004011
				CHK	ANG	±1/2°	FINISH
				RFP	PREV	SIZE	DRAWING NO
				NETWORK FILE NAME	00500303	A	005003-03
							REV
							06





**1051 CHEYENNE AVE.
GRAFTON, WI 53024
PH. 262-377-8810**

CERTIFICATION DATA SHEET

CONN. DIAGRAM: 005003.03
OUTLINE: 028774-550A
WINDING #: C634260 FR 3 A

CATALOG #: 113256.00
MOUNTING: F1 ONLY

TYPICAL MOTOR PERFORMANCE DATA

HP	kW	SYNC. RPM	F.L. RPM	FRAME	ENCLOSURE	KVA CODE	DESIGN
1/3	0.25	1800	1725	56	TEFC	M	L

PH	Hz	VOLTS	AMPS	START TYPE	DUTY	INSL	S.F.	AMB°C
1	60	115/208-230	6.4/3.4-3.2	ACROSS THE LINE	CONTINUOUS	B4	1.15	40

FULL LOAD EFF:	62	3/4 LOAD EFF:	57.3	1/2 LOAD EFF:	47.4	GTD. EFF	ELEC. TYPE
FULL LOAD PF:	55	3/4 LOAD PF:	49	1/2 LOAD PF:	41.5	57.5	CAP START IND RUN

F.L. TORQUE	LOCKED ROTOR AMPS	L.R. TORQUE	B.D. TORQUE	F.L. RISE°C
16 OZ-FT	30.8 / 15.4	60.5 OZ-FT 378 %	49.6 OZ-FT 310 %	61

SOUND PRESSURE @ 3 FT.	SOUND POWER	ROTOR WK^2	MAX. WK^2	SAFE STALL TIME	STARTS / HOUR	APPROX. MOTOR WGT
53 dBA	63 dBA	0.05 LB-FT^2	0 LB-FT^2	10 SEC.	0	23 LBS.

***** SUPPLEMENTAL INFORMATION *****

DE BRACKET TYPE	ODE BRACKET TYPE	MOUNT TYPE	ORIENTATION	SEVERE DUTY	HAZARDOUS LOCATION	DRIP COVER	SCREENS	PAINT
STANDARD	STANDARD	RIGID	HORIZONTAL	FALSE	NONE	FALSE	NONE	RED (ENAMEL)

BEARINGS		GREASE	SHAFT TYPE	SPECIAL DE	SPECIAL ODE	SHAFT MATERIAL	FRAME MATERIAL
DE	ODE						
BALL	BALL	POLYREX EM	STANDARD 56	NONE	NONE	1144 STRESSPROOF (C-223)	ROLLED STEEL
6203	6203						

THERMO-PROTECTORS				THERMISTORS	CONTROL	SPACE HEATERS
THERMOSTATS	PROTECTORS	WDG RTDs	BRG RTDs			
NONE	MANUAL	NONE	NONE	NONE	FALSE	NONE VOLTS

*
N
O
T
E
S
*

INVERTER TORQUE: NONE
INV. HP SPEED RANGE: NONE
ENCODER: NONE NONE NONE NONE NONE PPR
BRAKE: NONE NONE NONE P/N NONE NONE NONE NONE FT-LB NONE V NONE Hz



LEESON ELECTRIC CORPORATION
TYPICAL PERFORMANCE CURVE for AC MOTOR

Model No 113256.00

Catalog No 113256.00

Curve at 230 Volts HP 0.33 PHASE 1
60 HZ
0.33 HP VOLTS 115/208-230
HZ 60 RPM 1725

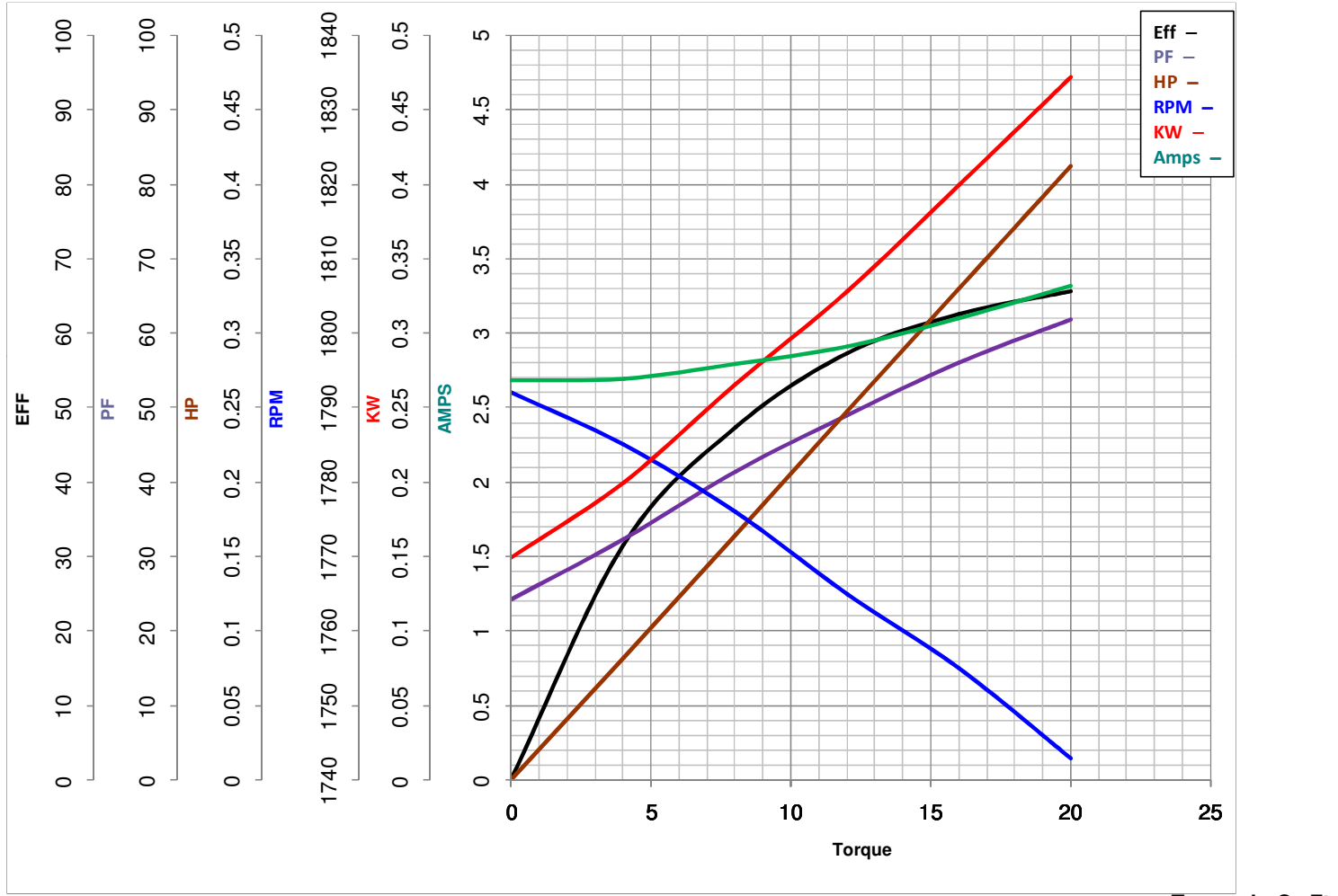

FL TORQUE	<u>16</u>	Oz.Ft	FL AMPS	<u>6.4/3.4-3.2</u>
BD TORQUE	<u>49.6</u>	Oz.Ft	PU TORQUE	<u>46.0</u> Oz.Ft
LR TORQUE	<u>60.5</u>	Oz.Ft	LR AMPS	<u>15.4</u>
WINDING	C634260-3		Date	<u>4/23/2018</u>