

PRODUCT INFORMATION PACKET

Model No: 117878.00

Catalog No: 117878.00

0.33 HP Agricultural Motor, 1 phase, 1800 RPM, 115/208-230 V, 56C Frame, TEFC



Regal and are trademarks of Regal Rexnord Corporation or one of its affiliated companies.
©2022 Regal Rexnord Corporation, All Rights Reserved. MC017097E

Nameplate Specifications

Output HP	0.33 Hp	Output KW	0.25 kW
Frequency	60 Hz	Voltage	115/208-230 V
Current	6.6/3.1-3.3 A	Speed	1725 rpm
Service Factor	1.15	Phase	1
Efficiency	55 %	Power Factor	60
Duty	Continuous	Insulation Class	B
Design Code	N	KVA Code	N
Frame	56C	Enclosure	Totally Enclosed Fan Cooled
Thermal Protection	Manual	Ambient Temperature	40 °C
Drive End Bearing Size	6203	Opp Drive End Bearing Size	6203
UL	Recognized	CSA	Y
CE	N	IP Code	43
Number of Speeds	1		

Technical Specifications

Electrical Type	Capacitor Start Induction Run	Starting Method	Across The Line
Poles	4	Rotation	Selective Counterclockwise
Resistance Main	0 Ohms	Mounting	Round
Motor Orientation	Horizontal	Drive End Bearing	Ball
Opp Drive End Bearing	Ball	Frame Material	Rolled Steel
Shaft Type	NEMA 56	Overall Length	11.82 in
Frame Length	6.56 in	Shaft Diameter	0.625 in
Shaft Extension	1.88 in	Assembly/Box Mounting	F1/F2 CAPABLE
Connection Drawing	A-102005-52-LE	Outline Drawing	A-100866LE-656

100866LE

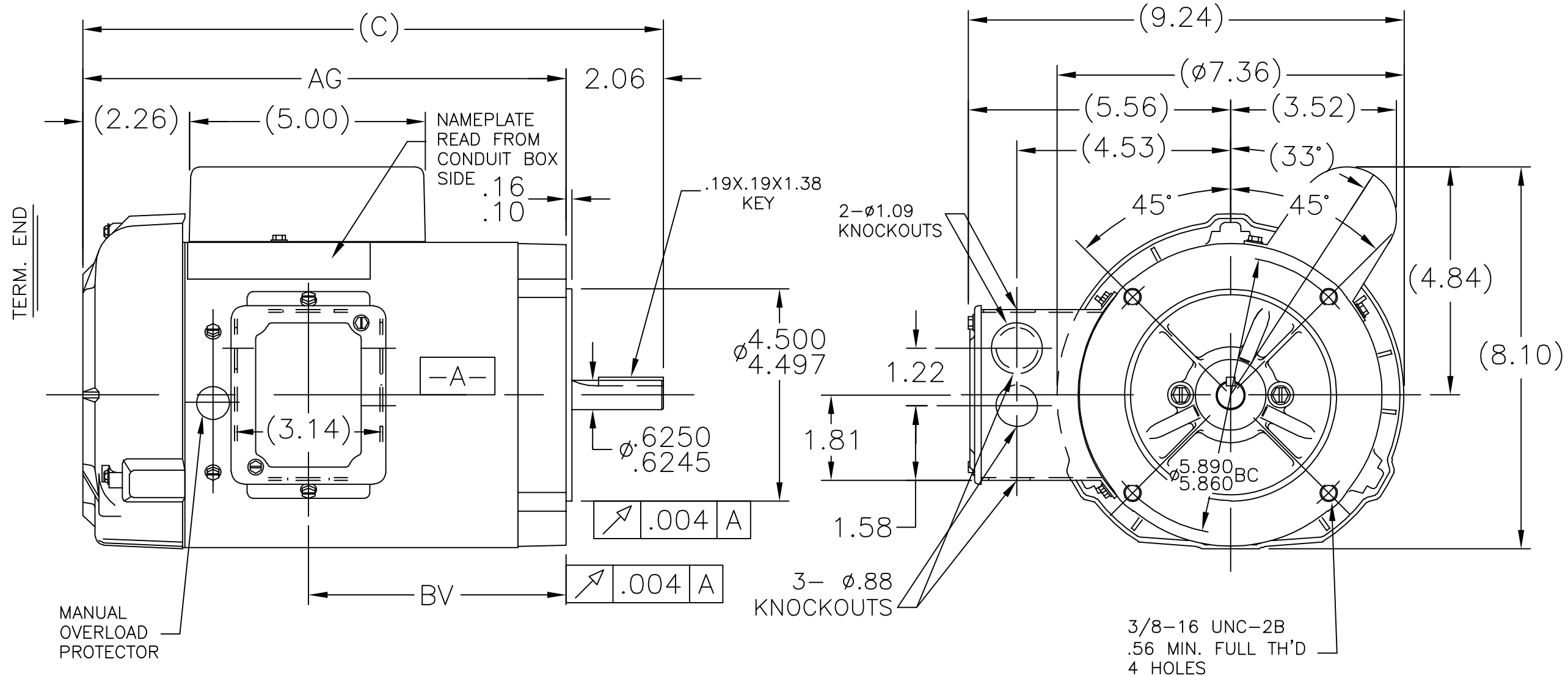

DASH	FR.	C	AG	BV	DASH	FR.	C	AG	BV
					806	56-80	13.32	11.25	6.47
656	56-65	11.82	9.75	4.97	856	"-85	13.82	11.75	6.97
706	"-70	12.32	10.25	5.47	906	"-90	14.32	12.25	7.47
756	"-75	12.82	10.75	5.97	956	"-95	14.82	12.75	7.97

NOTES:

1. CONDUIT BOX CAN BE ROTATED 180°
2. DRAIN HOLE AT 12 O'CLOCK IN C-FACE TO BE PLUGGED.
3. DRAIN HOLES AT 6 O'CLOCK BOTH ENDS ARE NOT TO BE PLUGGED.

ORACLE
REV 001

		TOLERANCES UNLESS SPECIFIED		LEESON	ELECTRIC MOTORS GEARMOTORS AND DRIVES	DRAWN LZ 03-19-1994	
		DEC.	INCHES			CHK ML 03-22-1994	APPD MS 03-22-1994
		.X	±.1	TITLE OUTLINE 56 FR - BB - TEFC - C FACE 1ø	SCALE 5=16		
		.XX	±.03		REF		
		.XXX	±.005		FMF		
		.XXXX	±.0005		PREV		
C	ADDED NOTES #2 & #3 ECR 0080066		GWS 4/29/15	MAT'L.			
NO.	REVISION		BY & DATE	CHK ANG ±7'30"	FINISH		
THIS DRAWING IN DESIGN AND DETAIL IS OUR PROPERTY AND MUST NOT BE USED EXCEPT IN CONNECTION WITH OUR WORK ALL RIGHTS OF DESIGN AND INVENTION ARE RESERVED THIS IS AN ELECTRONICALLY GENERATED DOCUMENT - DO NOT SCALE THIS PRINT				RFP	CAD FILE 100866LE	SIZE A	
				DIST WP		DRAWING NO. 100866LE	
						PAGE OF C	

LOW VOLTAGE - CCW

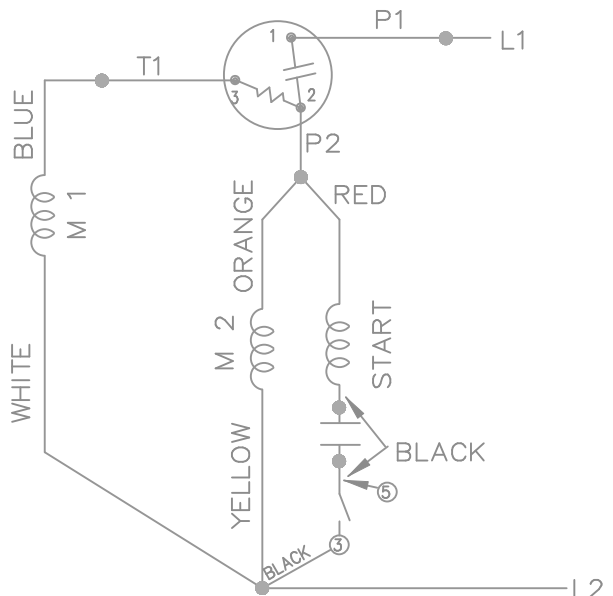

HIGH VOLTAGE - CCW

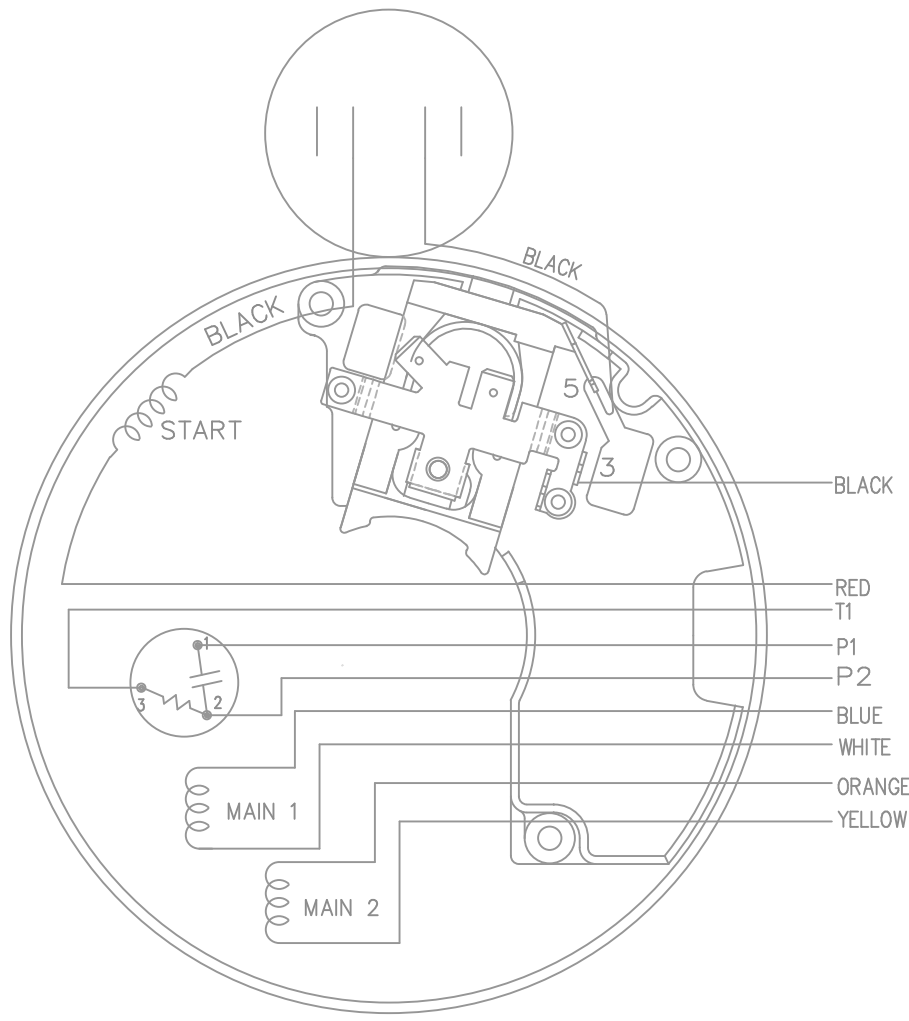
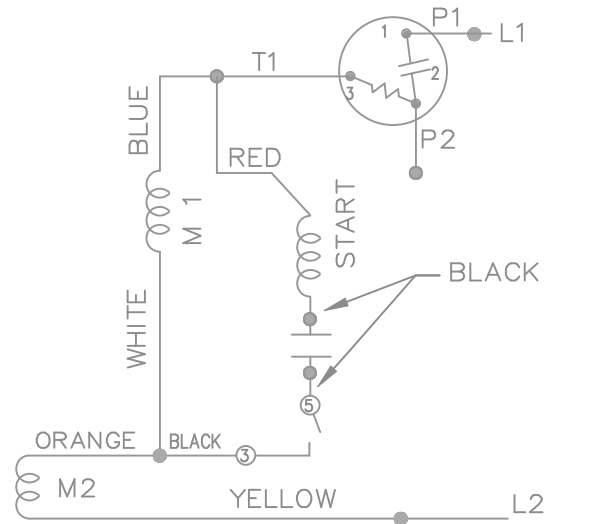

DUAL VOLTAGE
CAPACITOR START
OVERLOAD
SELECT ROTATION

LOW VOLT. CCW ROT.

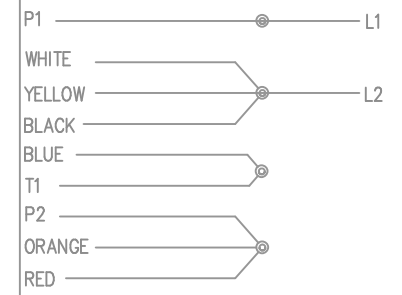

HIGH VOLT. CCW ROT.

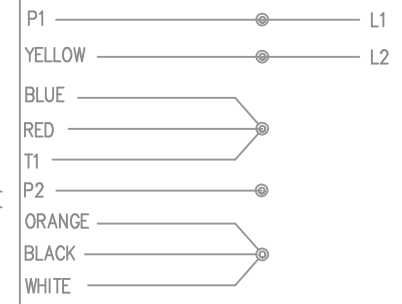

FOR CW ROTATION
EITHER VOLTAGE
INTERCHANGE RED
WITH BLACK

				TOLERANCES UNLESS SPECIFIED		 ELECTRIC MOTORS GEARMOTORS AND DRIVES	DRAWN NJS 09-03-2002		
				DEC.	INCHES		CHK ML 09-04-2002		
				.X	±.1		APPD GK 09-09-2002		
				.XX	±.02		SCALE 5=8		
				.XXX	±.005		REF		
1	NEW DRAWING	MU43222	NJS 09-09-2002	ML	.XXXX ±.0005	MAT'L.	FMF		
NO.	REVISION	BY & DATE	CHK	ANG	±7'30"	FINISH	PREV		
THIS DRAWING IN DESIGN AND DETAIL IS OUR PROPERTY AND MUST NOT BE USED EXCEPT IN CONNECTION WITH OUR WORK ALL RIGHTS OF DESIGN AND INVENTION ARE RESERVED THIS IS AN ELECTRONICALLY GENERATED DOCUMENT - DO NOT SCALE THIS PRINT				RFP	CAD FILE 102005-52-LE		SIZE	DRAWING NO. PAGE OF	REV.
				DIST	WP	A		102005-52-LE	1



**1051 CHEYENNE AVE.
GRAFTON, WI 53024
PH. 262-377-8810**

CATALOG #: 117878.00

CONN. DIAGRAM: A-102005-52-LE

OUTLINE: A-100866LE-656

MOUNTING: F1/F2 CAPABLE

WINDING #: ZC406 3

TYPICAL MOTOR PERFORMANCE DATA

HP	kW	SYNC. RPM	F.L. RPM	FRAME	ENCLOSURE	KVA CODE	DESIGN
1/3	0.25	1800	1725	56C	TEFC	N	N

PH	Hz	VOLTS	AMPS	START TYPE	DUTY	INSL	S.F.	AMB°C
1	60	115/208-230	6.6/3.1-3.3	ACROSS THE LINE	CONTINUOUS	B3	1.15	40

FULL LOAD EFF:	55	3/4 LOAD EFF:	50.5	1/2 LOAD EFF:	43.2	GTD. EFF	ELEC. TYPE
FULL LOAD PF:	60	3/4 LOAD PF:	50	1/2 LOAD PF:	42.7	50.5	CAP START IND RUN

F.L. TORQUE	LOCKED ROTOR AMPS	L.R. TORQUE	B.D. TORQUE	F.L. RISE°C
16 OZ-FT	32.4 / 16.2	55.7 OZ-FT 348 %	44.6 OZ-FT 279 %	53

SOUND PRESSURE @ 3 FT.	SOUND POWER	ROTOR WK^2	MAX. WK^2	SAFE STALL TIME	STARTS / HOUR	APPROX. MOTOR WGT
0 dBA	10 dBA	0 LB-FT^2	0 LB-FT^2	10 SEC.	0	23 LBS.

***** SUPPLEMENTAL INFORMATION *****

DE BRACKET TYPE	ODE BRACKET TYPE	MOUNT TYPE	ORIENTATION	SEVERE DUTY	HAZARDOUS LOCATION	DRIP COVER	SCREENS	PAINT
C-FACE	STANDARD	ROUND	HORIZONTAL	FALSE	NONE	FALSE	NONE	GRAY (POWDER)

BEARINGS		GREASE	SHAFT TYPE	SPECIAL DE	SPECIAL ODE	SHAFT MATERIAL	FRAME MATERIAL
DE	ODE						
BALL	BALL	POLYREX EM	T	NONE	NONE	1144 STRESSPROOF (C-223)	ROLLED STEEL
6203	6203						

THERMO-PROTECTORS				THERMISTORS	CONTROL	SPACE HEATERS
THERMOSTATS	PROTECTORS	WDG RTDs	BRG RTDs			
NONE	MANUAL	NONE	NONE	NONE	FALSE	NONE VOLTS

*
N
O
T
E
S
*

INVERTER TORQUE: NONE
INV. HP SPEED RANGE: NONE
ENCODER: NONE
NONE NONE
NONE NONE PPR
BRAKE: NONE NONE
NONE P/N NONE
NONE NONE
FT-LB NONE V NONE Hz



LEESON ELECTRIC CORPORATION
 TYPICAL PERFORMANCE CURVE for AC MOTOR

Model No 117878.00

Curve at 230 Volts HP 0.34 PHASE 1
60 HZ
0.333 HP VOLTS 115/208-230

Catalog No 117878.00

HZ 60 RPM 1725

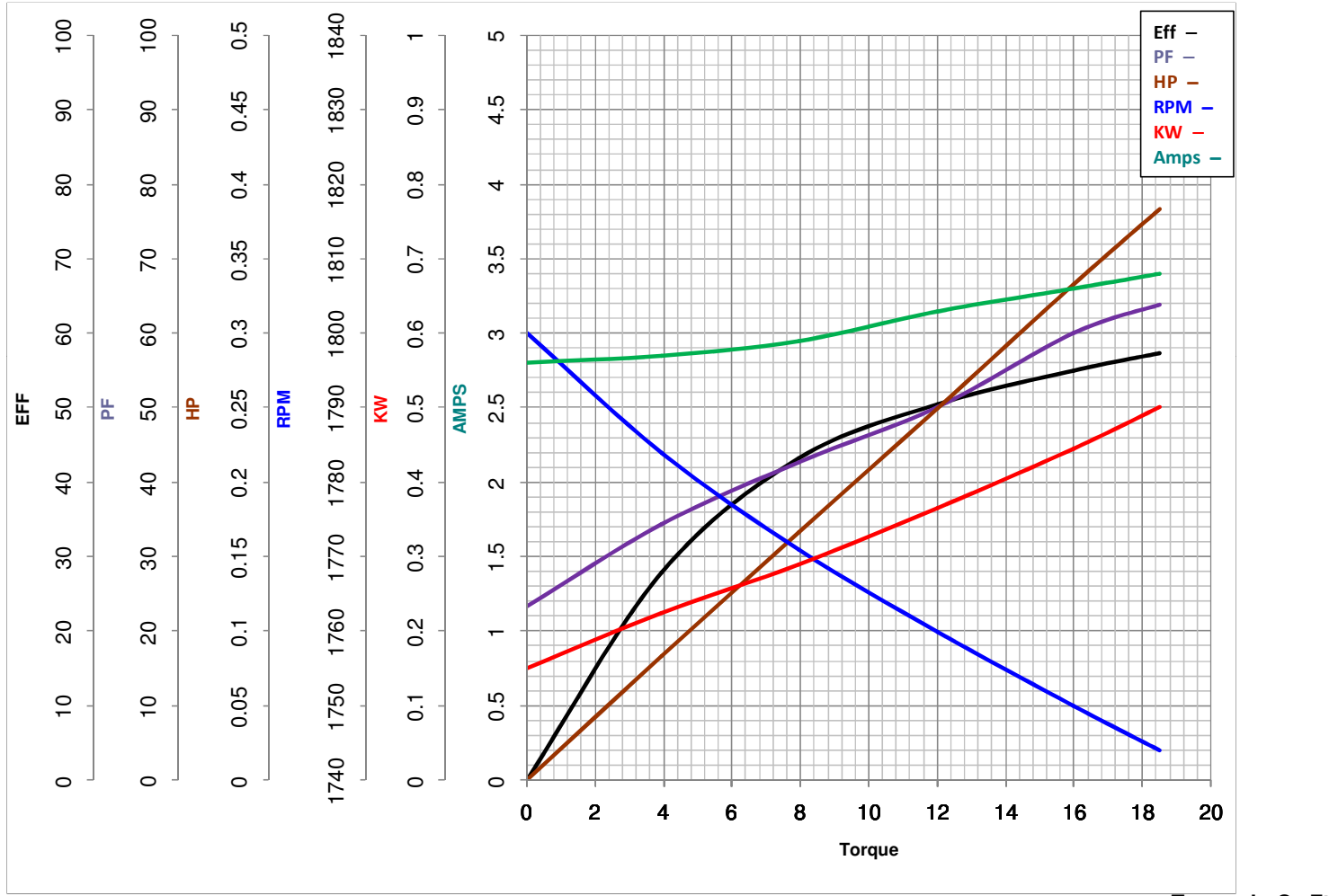

FL TORQUE	<u>16</u>	Oz.Ft	FL AMPS	<u>6.6/3.1-3.3</u>
BD TORQUE	<u>44.6</u>	Oz.Ft	PU TORQUE	<u>39.9</u> Oz.Ft
LR TORQUE	<u>55.7</u>	Oz.Ft	LR AMPS	<u>16.2</u>
WINDING	ZC406-3		Date	3/15/2018