

PRODUCT INFORMATION PACKET

Model No: 108092.00
Catalog No: 108092.00
SCR Motor, 1.50 HP, 180 V, 1750 RPM, S56C Frame, TEFC



Regal and are trademarks of Regal Rexnord Corporation or one of its affiliated companies.
©2022 Regal Rexnord Corporation, All Rights Reserved. MC017097E

Nameplate Specifications

Output HP	1.50 Hp	Output KW	1.1 kW
Voltage	180 V	Current	7.6 A
Speed	1750 rpm	Service Factor	1
Efficiency	86.5 %	Duty	Continuous
Insulation Class	H	Frame	S56C
Enclosure	Totally Enclosed Fan Cooled	Thermal Protection	No Protection
Ambient Temperature	40 °C	Drive End Bearing Size	6203
Opp Drive End Bearing Size	6203	UL	Recognized
CSA	Y	CE	N

Technical Specifications

Rotation	Reversible	Mounting	Rigid C base
Overall Length	16.82 in	Frame Length	9.47 in
Shaft Diameter	0.625 in	Shaft Extension	2.06 in
Torque	54 LB-IN		
Outline Drawing	031879-108092	Connection Drawing	00531901

This is an uncontrolled document once printed or downloaded and is subject to change without notice. Date Created:09/19/2022

RBC PROPRIETARY AND CONFIDENTIAL INFORMATION
 This document is the property of REGAL BELOIT CORPORATION ("RBC") including its subsidiaries and divisions and contains proprietary information of RBC. This document is based on the express condition that neither it nor the information contained therein shall be disclosed to others without the express written consent of RBC, and that the information shall be used by the recipient only as approved expressly by RBC. This document shall be returned to RBC upon its request. This document may be subject to certain restrictions under U.S. export control laws and regulations.

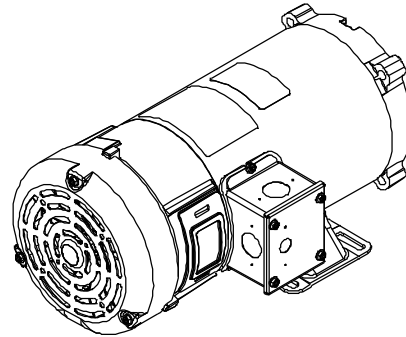
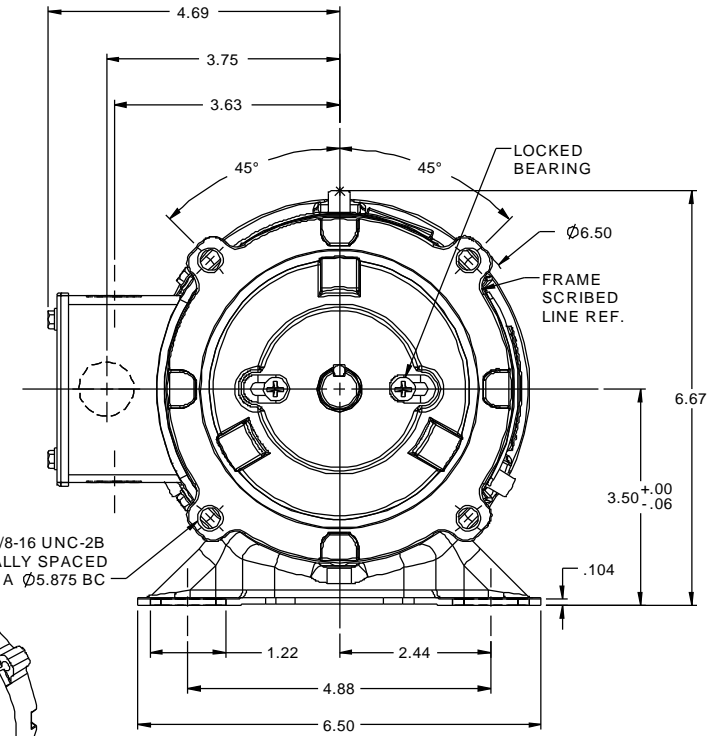
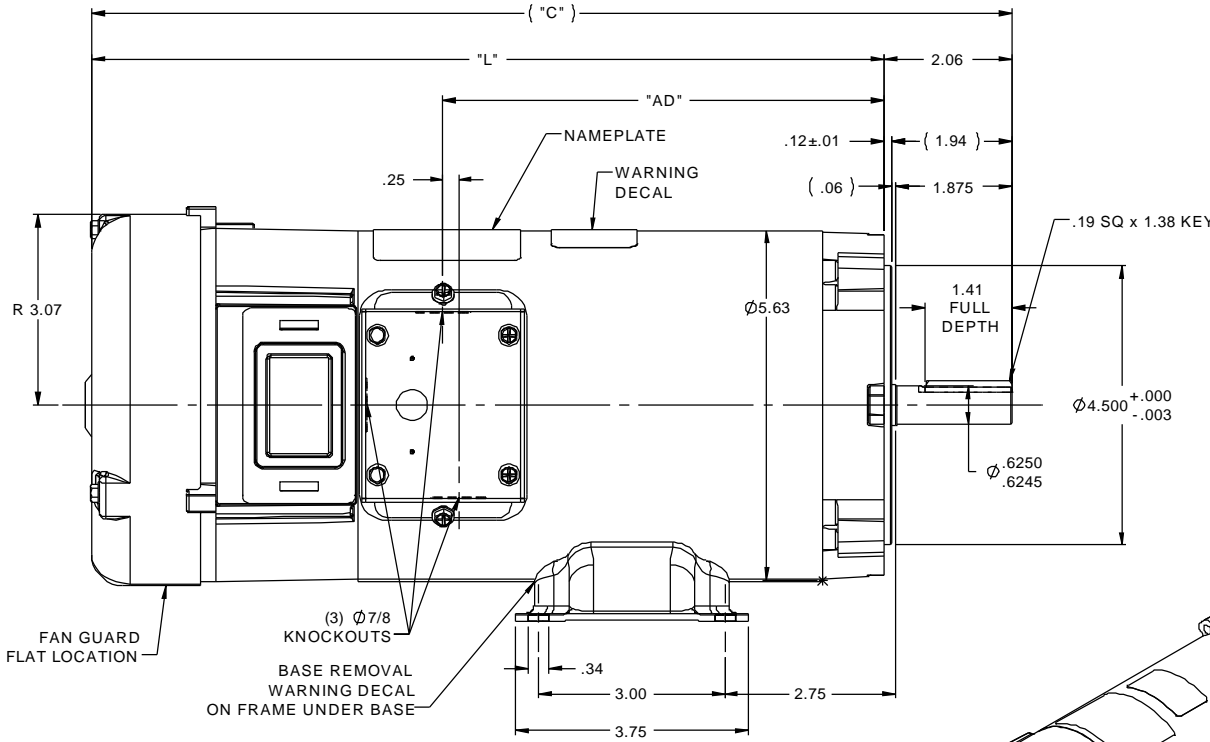

- NOTES:
 1) MAXIMUM FACE RUNOUT .004 T.I.R.
 2) MAXIMUM PILOT ECCENTRICITY .004 T.I.R.
 3) PERMISSIBLE SHAFT RUNOUT .002 T.I.R.
 4) GASKETS THROUGHOUT

109100.00	15.82	13.76	8.10	90	3/4	1140
109099.00	14.32	12.26	6.60	90	1/2	1140
109098.00	12.82	10.76	5.10	90	1/3	1140
108265.00	15.32	13.26	7.60	180	1 1/2	2500
108092.00	16.82	14.76	9.10	180	1 1/2	1750
108023.00	14.82	12.76	7.10	180	1	1750
108022.00	14.82	12.76	7.10	90	1	1750
108021.00	13.82	11.76	6.10	180	1	2500
108020.00	13.32	11.26	5.60	90	1	2500
108019.00	13.82	11.76	6.10	180	3/4	1750
108018.00	13.82	11.76	6.10	90	3/4	1750
108017.00	12.82	10.76	5.10	180	3/4	2500
108016.00	12.82	10.76	5.10	90	3/4	2500
108015.00	12.82	10.76	5.10	180	1/2	1750
108014.00	12.82	10.76	5.10	90	1/2	1750
CATALOG No.	"C"	"L"	"AD"	VOLTS	H.P.	RPM

06	CHANGED .06 & 1.94 DIMS TO REF., ISAAC 12-0984	IPG 1/30/2013	TOLERANCES UNLESS SPECIFIED							
05	ADDED NOTE ABOUT FAN GUARD LOCATION, ISAAC 09-4813	IPG 12/4/2009	DEC INCHES							
04	CAT. # 108092.00: "C" WAS 17.32, "L" WAS 15.26, "AD" WAS 9.60, ISAAC 09-1828	IPG 5/14/2009	X ±.1							
03	ADDED DATA FOR VARIOUS CAT. NUMBERS, COMPLETED	IPG 9/15/2008	XXX ±.005							
	TABLE		XXXX ±.0005							
NO	REVISION	BY & DATE	CHK LANG ±1/2°	FINISH						
			RFP	PREV						
	THIRD ANGLE PROJECTION									
			NETWORK FILE NAME	031879						
			SIZE	B	DRAWING NO	031879				
					REV	06				



ELECTRIC MOTORS
 GEARMOTORS
 AND DRIVES

DRAWN RWS 1/8/08
 CHK IPG 1/9/08
 APPR

TITLE OUTLINE
 48 FRAME DC - S56C MOUNT
 SCALE 1:2
 REF 031189.00
 FMF 108022.75
 PAGE OF

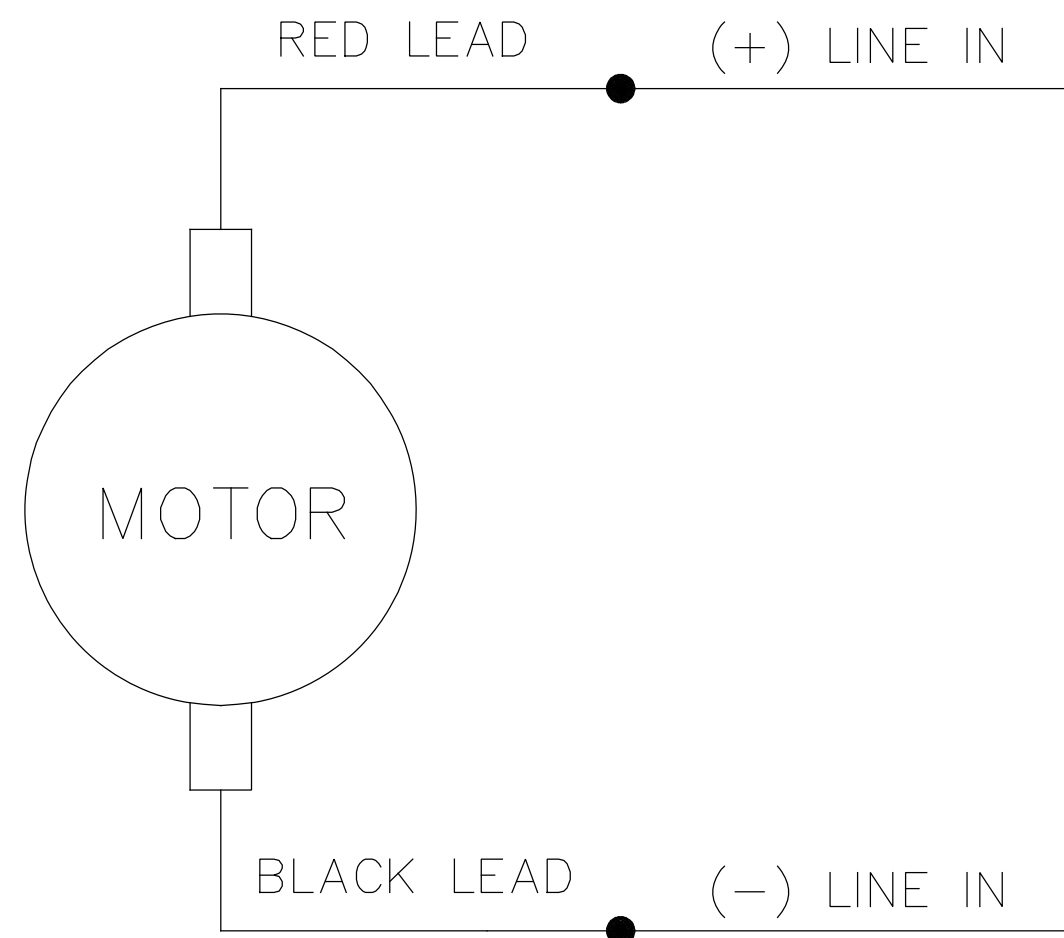

CONNECTIONS SHOWN FOR CCW ROTATION FACING LEAD END OF THE MOTOR
 TO REVERSE ROTATION INTERCHANGE LINE LEADS

NO.	REVISION	BY & DATE	CHK	TOLERANCES UNLESS SPECIFIED		LEESON	ELECTRIC MOTORS GEARMOTORS AND DRIVES	DRAWN TJF 11/15/97	
				DEC.	INCHES				CHK
				.X	±.1			APPD POW 11/15/97	
E	"MOTOR" WAS "ARMATURE", ECO-0163602	IPG 3/14/19		.XX	±.01	TITLE	EXTERNAL WIRING DIAGRAM PMDC MOTOR	SCALE 1=2	
D	UPDATED TO MAKE IT GENERIC, ECO-0163547	IPG 3/13/19		.XXX	±.005			REF	
01	REDRAWN ON CAD. REVISED NOTES.	SJB 9/20/2005		.XXXX	±.0005	MAT'L.		FMF	
				ANG	±1/2°	FINISH		PREV	
THIS DRAWING IN DESIGN AND DETAIL IS OUR PROPERTY AND MUST NOT BE USED EXCEPT IN CONNECTION WITH OUR WORK ALL RIGHTS OF DESIGN AND INVENTION ARE RESERVED THIS IS AN ELECTRONICALLY GENERATED DOCUMENT - DO NOT SCALE THIS PRINT				RFP	CAD FILE 00531901		SIZE A	DRAWING NO. 005319.01	REV. E
				DIST					

LEESON ELECTRIC CORPORATION

TYPICAL PERFORMANCE CURVE FOR DIRECT CURRENT PERMANENT MAGNET MOTOR

Model No. <u>C4D17FK10</u>	Catalog No. <u>108092.00</u>	
HP <u>1.500</u>	RPM <u>1750</u>	DC Volts <u>180.0</u>
F.F. <u>1.38</u>	Encl <u>TEFC</u>	Type <u>DF</u>
Max. Amb. <u>40.0 Deg C</u>	Insul. <u>H</u>	Frame <u>S56C</u>
		N.P. FLA <u>7.60</u>
		S.F. <u>1.00</u>
		Duty <u>Cont</u>

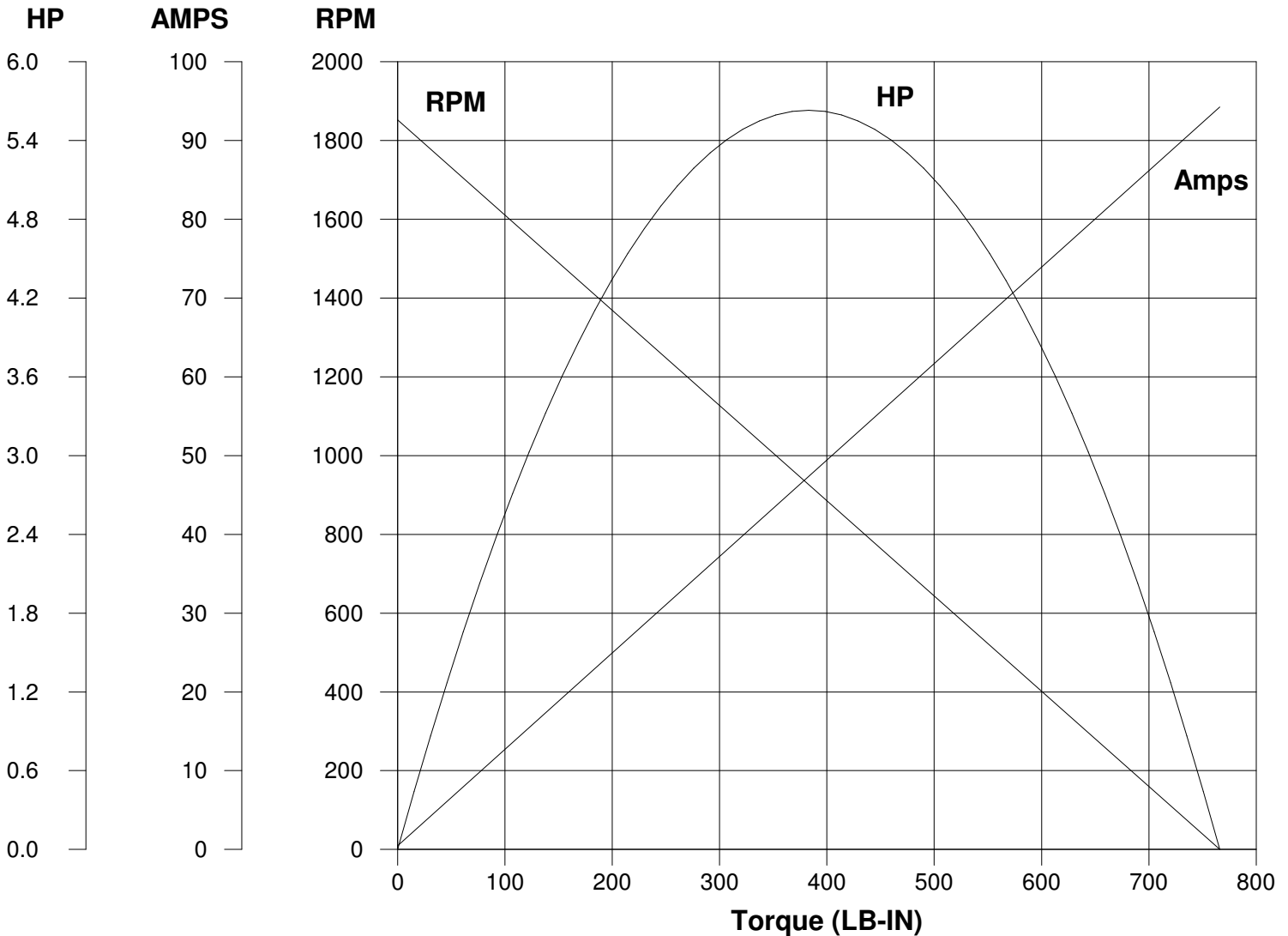

Ra <u>1.1000</u> Ohms La <u>22.50</u> mHenrys Ja <u>20.80</u> LB-IN ² Ke <u>96.67</u> V/KRPM	Kt <u>8.171</u> LB-IN/AMP Imax <u>68.8</u> AMPS Allowed FL Torque <u>54.00</u> LB-IN FL EFF <u>86.50</u> %
--	---

Winding W- D56275-1 Prepared by S. Bernhardt Date 09-09-2009