

Submersible Non-Clog Pumps

DISCHARGE	3" NPT, Female, Vertical, Bolt-on Flange
LIQUID TEMPERATURE	104°F (40°C) Continuous
VOLUTE	Cast Iron ASTM A-48, Class 30
MOTOR HOUSING	Cast Iron ASTM A-48, Class 30
SEAL PLATE	Cast Iron ASTM A-48, Class 30
IMPELLER: Design	2 Vane, open, with pump out vanes on back side. Dynamically balanced, ISO G6.3
<i>Material</i>	Cast Iron ASTM A-48, Class 30
SHAFT	416 Stainless Steel
SQUARE RINGS	Buna-N
HARDWARE	300 Series Stainless Steel
PAINT	Air Dry Enamel
SEAL: Design	Single Mechanical
<i>Material</i>	Carbon/Ceramic/Buna-N
CORD ENTRY	Hardware -300 Series Stainless
	30 ft. (9.1m) Cord. Plug on 120 Volt & .5HP. 240 Volt 1 Phase. Quick connect custom molded for sealing and strain relief
UPPER BEARING	Single Row, Ball, Oil lubricated
LOWER BEARING	Single Row, Ball, Oil lubricated
MOTOR: Design	NEMA L -Single Phase, NEMA B -Three phase
<i>Insulation</i>	Torque Curve, Oil Filled, Squirrel Cage Induction Class B
SINGLE PHASE	Class F on selected models
	Permanent Split Capacitor (PSC)
THREE PHASE	Includes Overload Protection in Motor
	200-240/480 is Tri-Voltage. 600V. Requires Overload Protection to be included in control panel
OPTIONAL EQUIPMENT	Seal Material, Impeller Trims, Additional cord, Normally Closed Temperature Sensors with cord for 3 phase pumps (Requires relay in control panel).
ACCESSORIES	Break Away Fitting (BAF) Check Valve Control Panel

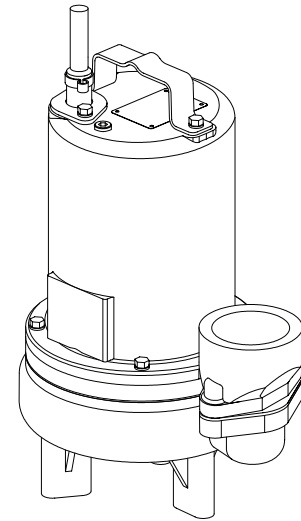

Series: 3SE-L

.5 - 1HP, 1750RPM, 60Hz



CSA 108 - File No. LR16567
UL 778

DESCRIPTION:
SUBMERSIBLE NON-CLOG SEWAGE PUMP DESIGNED FOR TYPICAL RAW SEWAGE APPLICATIONS

TOTAL HEAD
METERS FEET

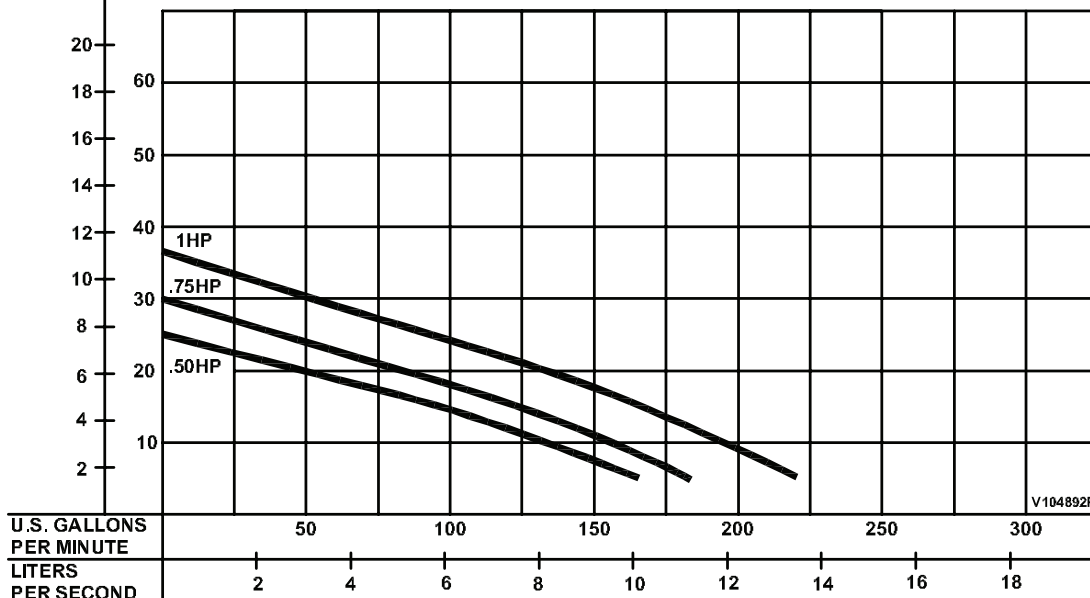

Testing is performed with water specific gravity of 1.0 @ 68°F (20°C), other fluids may vary performance



AMPRO ELECTRIC LTD.

www.shopampro.com | www.amproelectric.com | 1-800-361-3509

SECTION D
PAGE 25
DATE 11/15

Series 3SE-L

2" Spherical Solids Handling
Single Seal

Submersible Non-Clog Pumps

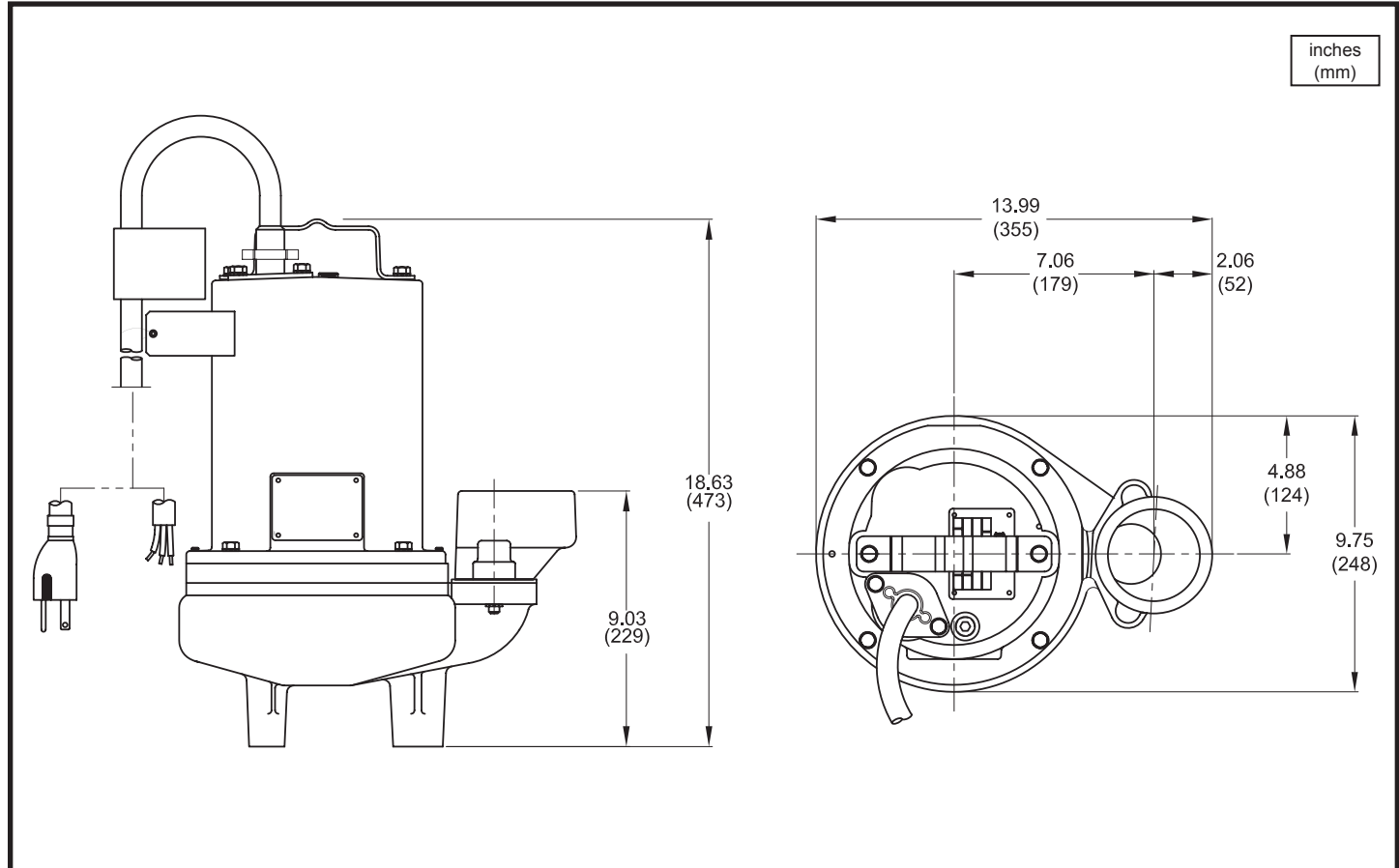

MODEL NO	PART NO	HP	VOLT/PH	Hz	RPM (Nom)	NEMA START CODE	INSUL. CLASS	FULL LOAD AMPS	LOCKED ROTOR AMPS	CORD SIZE	CORD TYPE	CORD O.D inch (mm)
3SE514L	104892	0.5	120/1	60	1750	F	B	11.6	21.3	14/3	SJTOW	0.375 (9.5)
3SE524L	104893	0.5	240/1	60	1750	J	B	5.9	14.9	14/3	SOW	0.530 (13.5)
3SE594L	104894	0.5	200-240/3	60	1750	H/L	B	3.2/3.0	9.8/11.0	14/4	SOW	0.570 (14.5)
3SE544L	104895	0.5	480/3	60	1750	K	B	1.5	5.3	14/4	SOW	0.570 (14.5)
3SE554L	104896	0.5	600/3	60	1750	H	B	1.0	3.4	14/4	SOW	0.570 (14.5)
3SE774L	104902	0.75	200-240/1	60	1750	G/K	F	7.4/7.0	21.5/25.8	14/3	SOW	0.530 (13.5)
3SE794L	104903	0.75	200-240/3	60	1750	H/K	B	4.8/4.5	13.7/15.4	14/4	SOW	0.570 (14.5)
3SE744L	104904	0.75	480/3	60	1750	K	B	2.2	7.7	14/4	SOW	0.570 (14.5)
3SE754L	104905	0.75	600/3	60	1750	L	B	1.5	7.2	14/4	SOW	0.570 (14.5)
3SE1074L	104910	1.0	200-240/1	60	1750	D/G	F	8.8/8.3	21.5/25.8	14/3	SOW	0.530 (13.5)
3SE1094L	104911	1.0	200-240/3	60	1750	E/H	B	5.14/4.9	13.7/15.4	14/3	SOW	0.570 (14.5)
3SE1044L	104912	1.0	480/3	60	1750	H	B	2.4	7.7	14/4	SOW	0.570 (14.5)
3SE1054L	104913	1.0	600/3	60	1750	J	B	1.9	7.2	14/4	SOW	0.570 (14.5)

OPTIONAL - Temperature sensor cord for 3 phase models is 14/3 SOW, 0.530 (13.5mm) O.D.

IMPORTANT !

- 1.) PUMP MAY BE OPERATED "DRY" FOR EXTENDED PERIODS WITHOUT DAMAGE TO MOTOR AND/OR SEALS.
- 2.) INSTALLATIONS SUCH AS DECORATIVE FOUNTAINS OR WATER FEATURES PROVIDED FOR VISUAL ENJOYMENT MUST BE INSTALLED IN ACCORDANCE WITH THE NATIONAL ELECTRIC CODE ANSI/NFPA 70 AND/OR THE AUTHORITY HAVING JURISDICTION. THIS PUMP IS NOT INTENDED FOR USE IN SWIMMING POOLS, RECREATIONAL WATER PARKS, OR INSTALLATIONS IN WHICH HUMAN CONTACT WITH PUMPED MEDIA IS A COMMON OCCURRENCE.

